



CONTROL PANEL

50B223-PFT Model Aerobic Control Panel

Features & Benefits

- Circuit Breakers for Pump, Compressor & Alarm Circuits
- Pressure Switch for Compressor Alarm
- 24 Hr Timer w/15 minute intervals
- Large & Easy to Access Terminal Block
- Externally Mounted Run/Mute/Test Switch w/UV resistant sealing boot
- Externally Mounted Audible Alarm
- Rugged UV resistant Externally Mounted Alarm Light
- Durable Weather Resistant Hinged Poly Enclosure
- Ground Lug
- Easily Replaceable Components
- Nema 4x Rating
- Color Coded Internal Wiring
- Built and Labeled to UL 508A Standard
- Works with most Aerobic Treatment Systems
- Provided with Wiring Schematic and Detailed Connection Diagram for Installer
- Mounting Feet for Enclosure
- Two year limited control panel warranty
- Externally Mounted Pump Test Switch

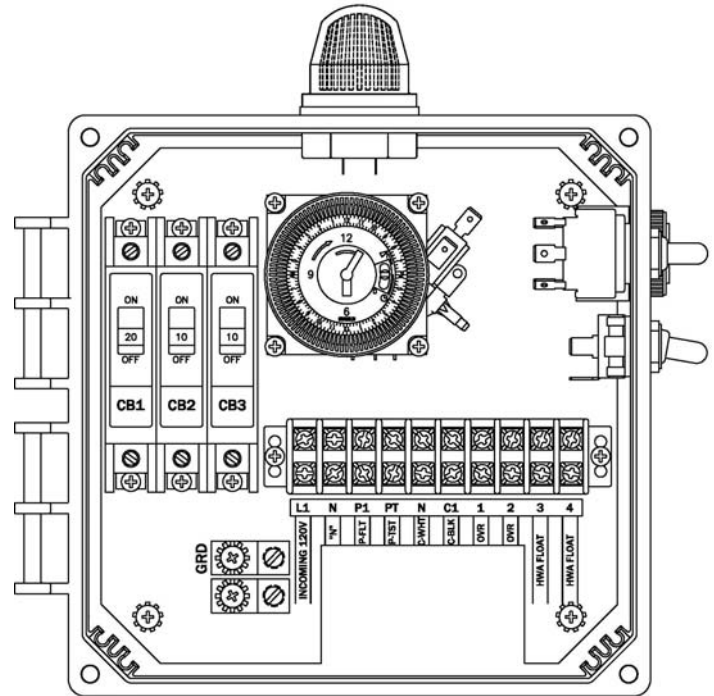

(50B223-PFT SHOWN)



Available Options

- Externally Mounted Air Pressure Switch
- Auto-Dialer
- Locking Stainless Steel Latch
- Repeat Cycle Timer Option
- Mercury or Mechanical Float Switches for the Pump and High Water Alarm Circuits

Note: Consult the factory for other available options. Also some options may require an increase in the enclosure size.

50B223-PFT Model Aerobic Control Panel

Panel Dimensions

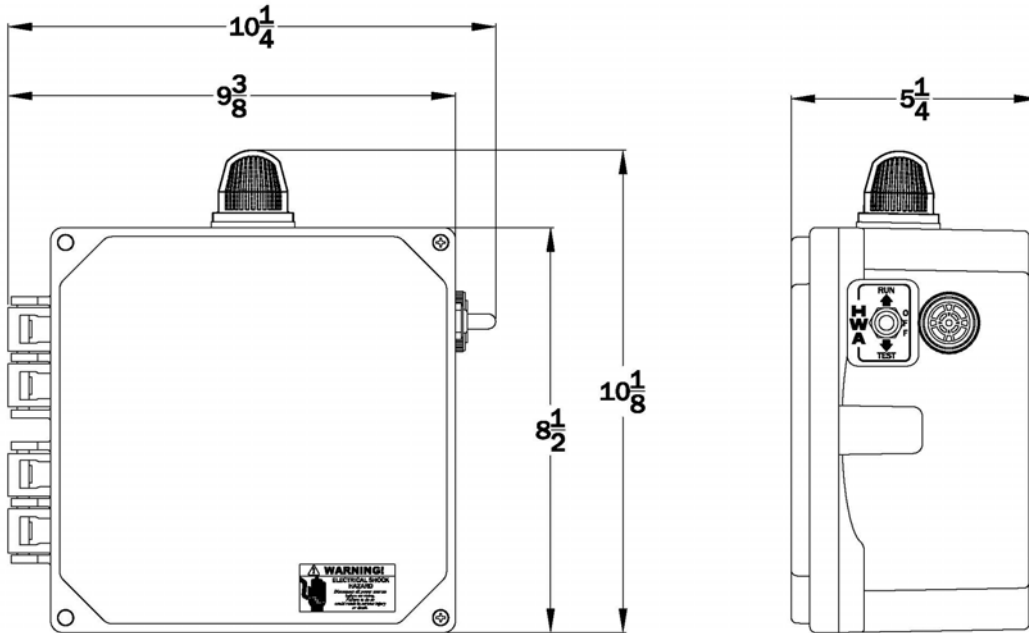

Wiring Schematic

