

norweco[®]

BIO-DYNAMIC[®]

SERIES 4000 TABLET FEEDER

INSTALLATION AND OPERATION MANUAL

INTRODUCTION

The Bio-Dynamic Series 4000 tablet feeder is a complete dry chemical dosing system for water or wastewater treatment. It is designed to provide precise control over chemical application and to maximize installation flexibility. All five (5) models of the Series 4000 will treat liquid flows from 20,000 gallons per day (GPD) to 200,000 GPD. For non-flow equalized wastewater applications, a peak flow factor of four will allow the feeder to be used in treatment plants with a design flow of up to 50,000 GPD. Constructed of heavy duty, UV rated polyethylene for maximum strength and durability, the feeder is entirely gravity fed with no electro-mechanical components. The feeder has a variable dosage capability depending upon general component configuration, the flow rate and the type of chemical tablets used. The Series 4000 tablet feeder is designed to provide long-term, unattended operation. To insure proper performance and maximize operational life, please take the time to familiarize yourself with the contents of this manual.

SYSTEM APPLICATION

The Series 4000 tablet feeder is designed for treatment systems that utilize 2⁵/₈" diameter molded chemical tablets. Applications include potable water, process water, wastewater, irrigation, municipal, reservoirs, water towers, cooling towers, as well as swimming pool backflush dechlorination. The system may be installed and adjusted for long-term chemical dosage in any of these applications. Each Bio-Dynamic has an internal fall of 1" to insure complete drainage of liquid from the flow deck. A built-in hydrodynamic mixing chamber provides maximum contact between the applied chemical and the liquid. This additional treatment step permits the Bio-Dynamic to be installed without secondary tankage where regulations allow.

HOW THE SERIES 4000 WORKS

Each model of the Series 4000 is a flow rated proportional feeder designed to safely apply chemicals into the flow of any treatment system. Flow enters through the integral 6" inlet hub and is channeled under an adjustable inlet baffle. Liquid proceeds to the flow deck where the chemicals are contained in four feed tubes. The flow deck has three levels (tiers) which accommodate varying hydraulic loading rates and channel liquid to the chemical tablets. Due to the configuration of the flow deck, the tablet feeder can effectively treat low, sustained, variable, intermittent and surge flows. Active chemicals are released as the liquid erodes the tablets. As the flow rate increases, the liquid level rises and contacts more tablets, thereby providing additional chemical release. The liquid is then channeled through an outlet weir or optional sluice to further regulate chemical application by controlling the liquid depth within the system. Properly treated liquid then flows out of the tablet feeder through the integral 6" outlet hub.



SERIES 4000 TABLET FEEDER

SYSTEM PERFORMANCE

A proven disinfection device for use with any treatment system, the Bio-Dynamic is listed as a certified chlorine dispenser under NSF/ANSI Standard 46. The Series 4000 tablet feeder is rated for flows up to 200,000 GPD, however, Standard 46 applies only to secondary effluent from residential wastewater treatment systems up to 1,500 GPD. Certification requires the use of Blue Crystal residential disinfecting tablets or Bio-Sanitizer disinfecting tablets and a chlorine contact tank of at least 11¹/₂ gallons. Contact tank retention time should be sufficient to comply with the controlling regulatory jurisdiction. USEPA guidelines state "On the average, satisfactory disinfection of secondary wastewater effluent can be obtained when the chlorine residual is 0.5 ppm after 15 minutes contact."

GENERAL INSTALLATION INSTRUCTIONS

The Bio-Dynamic Series 4000 tablet feeder can be installed in any treatment system, including direct burial, in-line and contact chamber mounting. The integrally molded inlet and outlet hubs allow direct connection to 6" Schedule 40 PVC piping. A standard coupling is required to make the connection watertight. If the treatment system piping is not 6", adapter couplings should be used. The system is self-draining and must always be installed plumb and level to insure proper operation. Place a bubble level on the feeder before final installation to confirm that the unit is plumb and level. For wastewater chlorination applications, the feeder should be installed downstream of the treatment system but upstream of the chlorine contact tank. For dechlorination applications, the feeder should be installed at a location immediately downstream of the chlorine contact tank. The Bio-Dynamic data chart at the bottom of this page lists the dimensions of the different models in the 4000 Series.

INSTALLATION AT GRADE

The tablet feeder can be installed at grade, in-line, or mounted in the contact tank of a water or wastewater treatment system. The installation should be accessible for routine maintenance. To mount the unit, use $\frac{3}{8}$ " diameter corrosion resistant bolts to secure the four integrally molded mounting feet to the deck of the contact tank, concrete pad or mounting brackets, as required. For contact tank installations, use PVC or aluminum mounting brackets to prevent corrosion. To protect the system from flow back-up during a severe hydraulic surge, there must be a minimum of 3" free fall from the unit outlet to the liquid level in the tank. After bolting the unit in place, check for level from side to side and end to end to confirm that fall through the system has been maintained. Make sure the feeder and all other treatment processes are secured for safety and to prevent unauthorized access.

DIRECT BURIAL INSTALLATION

The tablet feeder may be installed below grade without a manhole or secondary enclosure. The internal fall through the system and molded outlet hub eliminate the need for an external drop box. Safety/reinforcing struts are included in all direct burial models to insure system safety and strength. To install the tablet feeder in a direct burial application, prepare the excavation to 4" below the operational depth. Install a sand or fine gravel pad 4" thick and be sure that the pad is level. Place the feeder in the excavation and connect the inlet and outlet hubs using the proper couplings. Place each of the safety/reinforcing struts in position. When only two struts can be used, they must be side by side in the top retaining bosses adjacent to the feeder lid. Check the system for level and then carefully backfill the installation. When complete, the top of the tablet feeder lid must be at least 6" above grade to prevent groundwater infiltration. Remote removal systems are included with each Model ITR 4000-S to allow access to feed tubes in direct burial installations.

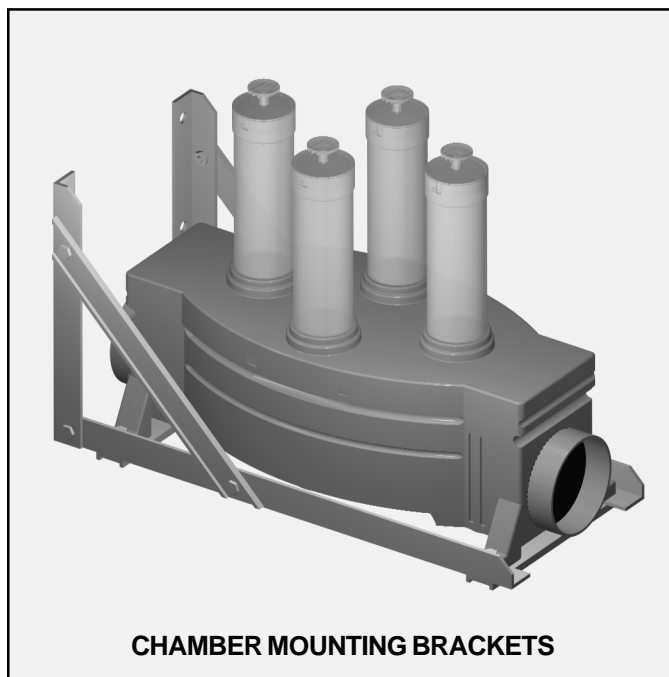

CHAMBER MOUNTING BRACKETS

BIO-DYNAMIC® SERIES 4000 DATA CHART

Model	Length	Width	Feeder Body Height Minimum Maximum	Fixed Weir	Adjustable Sluice	Installation Position	Drawing Number
XT 4000	35¾"	14½"	12" 18"	Yes	No	At Grade	PC-5-9503
XT 4000-S	35¾"	14½"	12" 18"	No	Yes	At Grade	PC-5-9503
IT 4000	35¾"	14½"	24" 24"	Yes	No	At Grade or Direct Burial	PC-5-9504
IT 4000-S	35¾"	14½"	24" 24"	No	Yes	At Grade or Direct Burial	PC-5-9504
ITR 4000-S	35¾"	14½"	30" 120"	No	Yes	Direct Burial	PC-5-9505

ACCESS RISERS

On below grade installations, 24" access risers are available that connect directly to the feeder body and utilize the standard lid. Drive rivets and sealant are provided with each riser to properly secure and seal the riser joint. The feeder and risers have drill points for placement of the drive rivets. Sixteen drive rivets connect the riser assembly. To install a riser, snap the riser section onto the feeder body. Using a 1/4" bit, drill completely through the riser and feeder at the drill point on the left-hand inlet end. Install a drive rivet in this hole and tap the stem flush. Check the feeder and riser from side to side to be sure they are vertically aligned. Drill a hole in the right-hand inlet end, opposing the first. Install the second drive rivet. Level the riser and feeder from end to end and drill the drill point on the left-hand outlet end. Install the drive rivet and repeat same on right-hand outlet end. Recheck alignment side to side and end to end. Now that the corners are secure, drill and install the remaining drive rivets along each side of the system. Seal the joint inside and outside according to the directions on the sealant label. Bio-Dynamic sealant is specially formulated and will not chemically react with chlorine tablets. Do not use other sealant products. Allow the sealant to cure for 24 hours before filling the feed tubes. Multiple risers may be used to allow deeper installation. Repeat these instructions for each additional riser installed.

Four safety/reinforcing struts are installed in each riser. To insure system strength and to prevent entry into the access risers, one strut must be located every 12" of system depth. Trim lines are located at 6" vertical increments on the feeder and riser to allow reduction of system height. Remove the lid and feed tubes before trimming the unit. Cut only along the trim line and remove all burrs and flash around the entire top of the unit. Reinstall any struts from the cut off section into the newly trimmed body and riser. Two side by side struts must be installed in the top retaining bosses adjacent to the unit lid.

SELECTING COMPONENT CONFIGURATION

The anticipated flow rate and desired chemical application rate of the system should be estimated to properly configure the tablet feeder for operation. The plant flow rate can be determined by engineering design estimates or by using a system flow meter, lift station capacity with number of pumping cycles, flow counter or water meter records. The adjustability of an inlet baffle and outlet weir or sluice gives Bio-Dynamic Series 4000 tablet feeders much greater control over chemical application than standard fixed-weir tablet feeders. The adjustability of the Series 4000 will allow the plant operator to control chemical application by adjusting weir width and baffle height without changing the position or number of feed tubes. Once the feeder is on-line, the primary methods used to regulate chemical dosage are to modify the weir or sluice width and/or adjust the inlet baffle.

BIO-DYNAMIC® SERIES 4000 TABLET FEEDER COMPONENT CONFIGURATION

Flow (GPD)	Less than 5 ppm Chlorine Demand					5 to 15 ppm Chlorine Demand					More than 15 ppm Chlorine Demand				
	Resid	Baffle	Weir	Sluice	Days	Resid	Baffle	Weir	Sluice	Days	Resid	Baffle	Weir	Sluice	Days
20,000	1.0	1 1/2	2"	2-2 1/4"	24	1.0	1 3/4	1"	1 1/2-1 3/4"	16	1.0	2	1"	1 1/2-1 3/4"	11
	1.5	1 1/2	2"	2-2 1/4"	23	1.5	1 3/4	1"	1 1/4-1 1/2"	15	1.5	2	1"	1 1/4-1 1/2"	10
	2.0	1 1/2	2"	1 3/4-2"	22	2.0	1 3/4	1"	1-1 1/4"	14	2.0	2	1"	1-1 1/4"	10
25,000	1.0	1 3/4	2"	2-2 1/4"	21	1.0	2	2"	2-2 1/4"	14	1.0	2 1/4	1"	1 1/2-1 3/4"	9
	1.5	1 3/4	2"	2-2 1/4"	20	1.5	2	2"	2-2 1/4"	13	1.5	2 1/4	1"	1 1/4-1 1/2"	9
	2.0	1 3/4	2"	1 3/4-2"	19	2.0	2	2"	1 3/4-2"	12	2.0	2 1/4	1"	1-1 1/4"	8
30,000	1.0	2	2"	2-2 1/4"	18	1.0	2 1/4	2"	2-2 1/4"	12	1.0	2 1/2	2"	2-2 1/4"	8
	1.5	2	2"	2-2 1/4"	17	1.5	2 1/4	2"	2-2 1/4"	11	1.5	2 1/2	2"	2-2 1/4"	7
	2.0	2	2"	1 3/4-2"	16	2.0	2 1/4	2"	1 3/4-2"	10	2.0	2 1/2	2"	1 3/4-2"	7
35,000	1.0	2 1/4	2"	2-2 1/4"	15	1.0	2 1/2	2"	2-2 1/4"	10	1.0	2 3/4	2"	2-2 1/4"	6
	1.5	2 1/4	2"	2-2 1/4"	14	1.5	2 1/2	2"	2-2 1/4"	9	1.5	2 3/4	2"	2-2 1/4"	6
	2.0	2 1/4	2"	1 3/4-2"	13	2.0	2 1/2	2"	1 3/4-2"	8	2.0	2 3/4	2"	1 3/4-2"	5
40,000	1.0	2 1/2	3"	2 3/4-3"	12	1.0	2 3/4	3"	2 3/4-3"	8	1.0	3	2"	2-2 1/4"	5
	1.5	2 1/2	3"	2 1/2-2 3/4"	11	1.5	2 3/4	3"	2 1/2-2 3/4"	7	1.5	3	2"	2-2 1/4"	4
	2.0	2 1/2	3"	2 1/4-2 1/2"	10	2.0	2 3/4	3"	2 1/4-2 1/2"	6	2.0	3	2"	1 3/4-2"	4
45,000	1.0	2 3/4	3"	2 3/4-3"	9	1.0	3	3"	2 3/4-3"	6	1.0	3 1/4	3"	2 3/4-3"	3
	1.5	2 3/4	3"	2 1/2-2 3/4"	8	1.5	3	3"	2 1/2-2 3/4"	5	1.5	3 1/4	3"	2 1/2-2 3/4"	3
	2.0	2 3/4	3"	2 1/4-2 1/2"	7	2.0	3	3"	2 1/4-2 1/2"	4	2.0	3 1/4	3"	2 1/4-2 1/2"	2
50,000	1.0	3	3"	2 3/4-3"	6	1.0	3 1/4	3"	2 3/4-3"	4	1.0	3 1/2	3"	2 3/4-3"	2
	1.5	3	3"	2 1/2-2 3/4"	5	1.5	3 1/4	3"	2 1/2-2 3/4"	3	1.5	3 1/2	3"	2 1/2-2 3/4"	1
	2.0	3	3"	2 1/4-2 1/2"	4	2.0	3 1/4	3"	2 1/4-2 1/2"	2	2.0	3 1/2	3"	2 1/4-2 1/2"	1

The feeder component chart above defines the preliminary configuration for inlet baffle, weir and sluice to satisfy the differing flow rates, chlorine demands and desired residuals as shown. These figures assume 70% available chlorine, as in Bio-Sanitizer chlorination tablets. In applications other than wastewater chlorination, regulate chemical dosage by changing the system configuration according to the results of effluent samples taken. The built-in flexibility of the Series 4000 tablet feeder should be utilized for final adjustments after the system is placed into operation and chemical dosage samples can be taken.

ADJUSTABLE INLET BAFFLE

All flow entering the tablet feeder is channeled under an adjustable inlet baffle. The inlet baffle is held in place by vertical support ribs molded into the body of the unit and is provided to protect the system from hydraulic surges. The inlet baffle can be adjusted from a 1" to 3 1/2" height. For most applications, the bottom of the inlet baffle should be 1/4" below the average liquid level. Raising the inlet baffle will increase chemical dosage. For installations at grade, the baffle height can be set by hand with a standard tape measure. For direct burial applications, a threaded baffle adjustment tool is available from your local Bio-Dynamic distributor. Thread the adjustment tool into the extension handle to adjust the baffle from any installation depth.

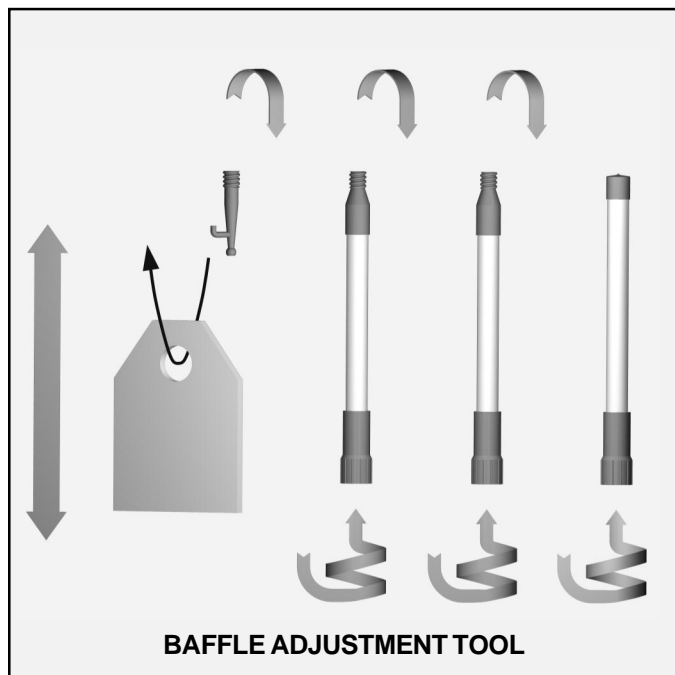

TIERED FLOW DECK

The multi-tiered flow deck of the Series 4000 tablet feeder allows consistent chemical application to low, sustained, variable, intermittent and surge flows. Liquid is channeled through the three tiers of the flow deck according to the hydraulic load. In low flows, liquid is directed toward the feed tubes to accomplish the desired chemical dosage. In higher flows, liquid is directed across the entire width of the feeder to maintain the chemical dosage level. The lowest tier of the flow deck is the inert drainage tier. The inert drainage tier directs liquid to the feed tubes during low flow conditions and forms a drainage channel to dry the tablets when there is no flow. As the flow increases up to 3 gallons per minute, the liquid is channeled through the intermediate flow tier, contacting more tablets. The shape of this tier causes the flow to accelerate as it passes the feed tubes. At flow rates over 3 gallons per minute, the liquid rises to the upper flow tier which dissipates the flow velocity and produces a consistent chemical dosage. The flow deck automatically channels these variable flows through the appropriate tier as shown in the sketch on page 7.

STATIONARY INSERT

The Series 4000 has a stationary insert that holds the internal components of the tablet feeder in place. The stationary insert has tapered locating holes to properly position and support the chemical feed tubes when installed. On all models, the insert is open on the inlet end to facilitate the adjustment of the inlet baffle. For models incorporating the standard weir plates, the stationary insert does not extend all the way to the outlet end wall of the tablet feeder. This section is left open to allow for the removal and replacement of weir plates. In models incorporating the optional outlet sluice, the insert extends completely to the outlet end wall. The sluice sections are held in proper position by the stationary insert. A molded hex nut on the top of each sluice section protrudes through the insert to hold the sluice in place and allow for adjustment. Indicator pins attached to the hex nuts show the sluice opening in inches on a scale engraved into the top of the stationary insert. The stationary insert is securely riveted to the body of the Bio-Dynamic Series 4000 tablet feeder at the factory.

FIXED WEIR

The tablet feeder is supplied with interchangeable 1", 2" and 3" outlet weir plates. Decreasing the width of the weir will raise the liquid level in the feeder and increase the chemical dosage. The outlet weir plates slide into vertical support

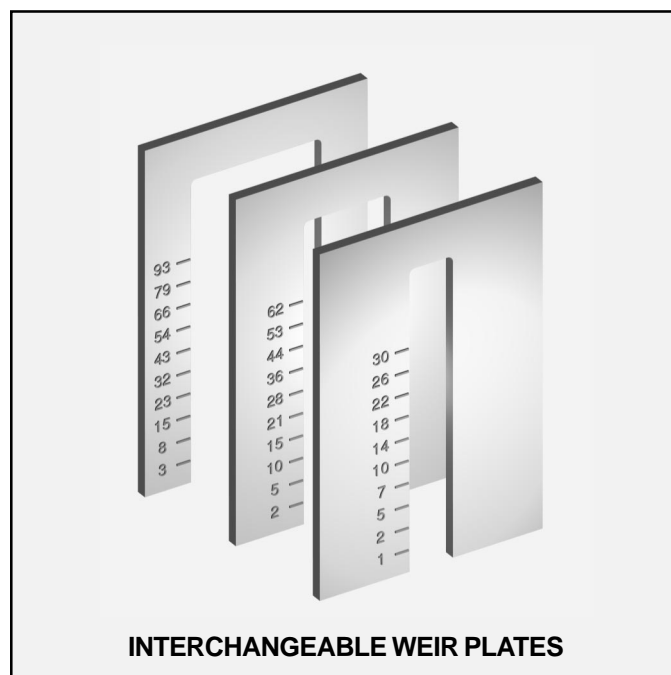

ribs molded into the tablet feeder body and engage into a channel in the flow deck. There is no need for external fasteners or adhesive to install the weir plates. The stationary insert is open at the outlet end of the flow deck to facilitate interchangeability of the weir plates. When installing a weir plate, make sure the plate is completely engaged in the support ribs and firmly against the flow deck. To change a weir plate, lift vertically to remove the weir and push down evenly to install the new plate.

ADJUSTABLE OUTLET SLUICE

The optional outlet sluice can be completely adjusted from a 1" to 3" width and provides precise control over chemical dosage. Chemical application can be customized to meet specific treatment requirements by using the outlet sluice. Decreasing the width of the sluice will raise the liquid level in the unit and increase the chemical dosage. The stationary insert extends completely to the feeder outlet to hold the sluice in position. The right and left sections of the sluice are synchronized by molded gears that assure accurate adjustment. Adjust the sluice by rotating one of the molded hex nuts that are located at the top of each sluice segment. The hex nuts protrude through the stationary insert and can be rotated with a standard 1" socket. Indicator pins on the hex nuts show the sluice opening in inches on a scale

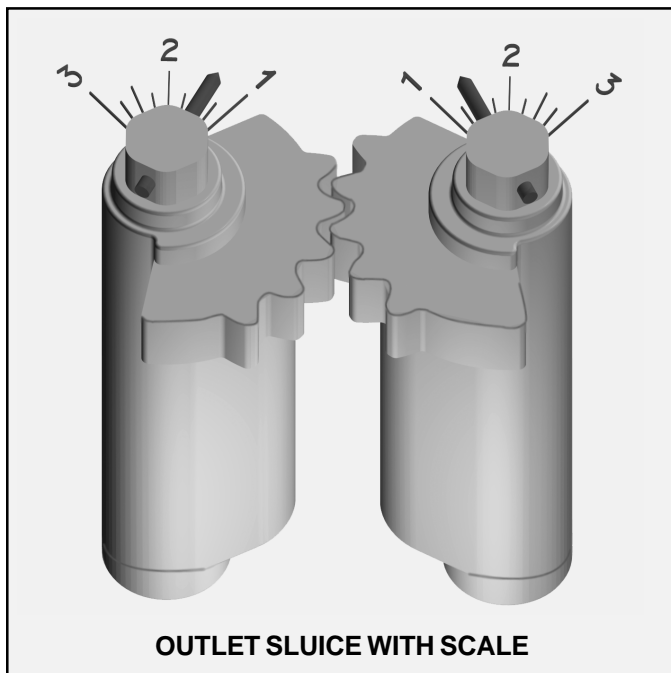

engraved into the top of the stationary insert. Each tablet feeder utilizing one or more riser sections for direct burial will include an adjustable outlet sluice. Follow these steps to adjust the outlet sluice:

1. Remove the feeder lid.
2. Place a 1" socket with the appropriate extension handle over one of the hex nuts that protrude through the stationary insert.
3. Rotate the hex nut toward the outside of the feeder to increase sluice width or toward the inside of the feeder to decrease sluice width. The indicator pins show the opening in inches on the engraved scale.
4. If you have rotated the hex nut too far, simply move the socket to the other hex nut and rotate the sluice back to the desired position.
5. Wait at least one hour and sample the effluent. If additional adjustment is necessary, repeat steps 1-4.
6. If the desired adjustment is not accomplished, see the Chemical Application section of this manual.
7. Note setting on service record and replace lid.

FILLING AND INSTALLING FEED TUBES

Before handling any chemical tablets, carefully read the product container label and the **CAUTION** section of these instructions. When filling feed tubes, always wear rubber gloves and safety goggles or a face shield for proper protection. Follow all handling instructions for the chemical tablets used. To fill the feed tube:

1. Remove feed tube from the tablet feeder.
2. Rinse feed tube and cap thoroughly with fresh water. Dry as required.
3. Hold tube, slotted end up, at a 30° to 45° angle and slide tablets into the open feed tube, one tablet at a time.
4. Insure that each tablet lies flat, against the next and evenly on top of one another, in the feed tube.
5. Use a gloved hand to retain the tablets inside the open end of the inverted tube until it has been completely filled.
6. Carefully return the tube to the upright position.
7. Replace cap and slide feed tube through the stationary insert and into the retaining rings in the flow deck.
8. Align the two vertical parting lines, one on each side of the tube, with the direction of flow through the feeder.
9. Insure the notches in the top of the feed tube are perpendicular to the flow direction. The window portions at the bottom of the feed tube will now be facing upstream and downstream respectively.

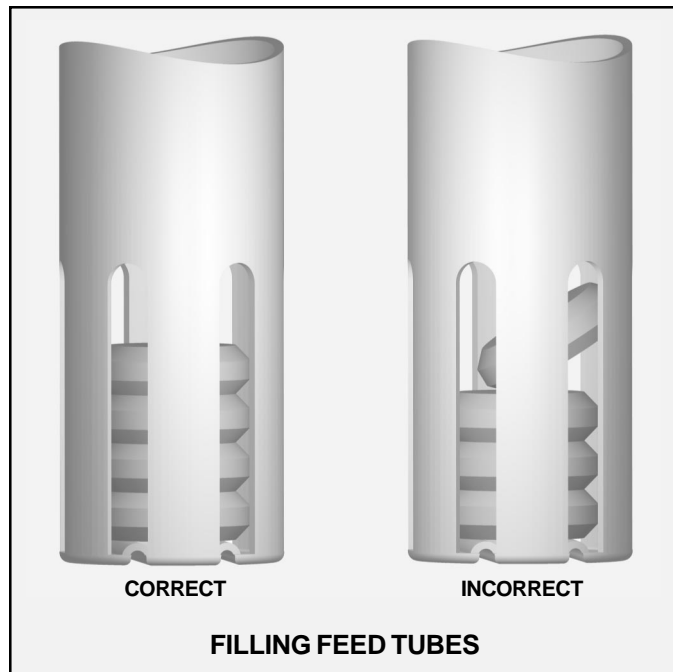

The precise control provided by the Series 4000 tablet feeder allows adjustment of the chemical application with all feed tubes filled and installed. Feed tubes should be refilled at the approximate intervals suggested in the Series 4000 Component Configuration chart on page 3 of this manual. Each installation will have an individual chemical consumption pattern which should be monitored during the initial weeks of operation to establish a firm refill schedule. Utilize the Chemical Consumption Record on the back of this manual to track your refill pattern.

REMOTE REMOVAL SYSTEM

A remote feed tube removal system is available for direct burial installations to allow for safe removal, recharge and reinstallation of the chemical feed tubes from grade. The remote removal system consists of four top-threaded feed tube caps, four corrosion resistant extensions and four corrosion resistant handles. For use, replace the standard cap with the top-threaded cap. The top-threaded cap locks into the feed tube and then the extension and handle are threaded onto the top of the new cap. The feed tube is then returned to its proper position within the tablet feeder. Additional

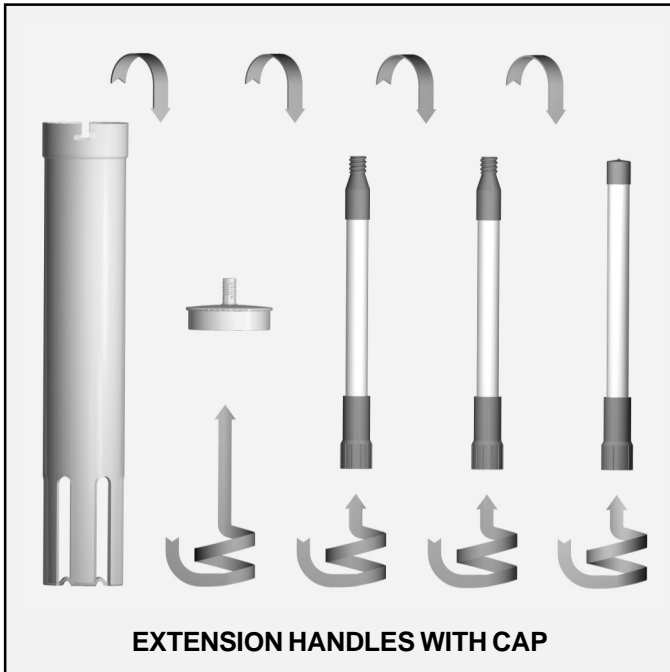

extensions are available for deeper installations and can be added or removed any time. The extensions and handles remain in place during system operation and standard feed tube filling instructions apply. A baffle adjustment tool is available that threads into the extension handle in the same manner as the top-threaded caps. To adjust the baffle, remove one feed tube and extension handle. Remove the handle from the feed tube and thread the handle onto the baffle tool. Place the hook portion of the tool through the hole in the inlet baffle. Adjust the baffle up or down as shown in the sketch on page 4.

FEED TUBE CLEANING BRUSH

A brush for cleaning the feed tubes and flow deck is available from your local Bio-Dynamic distributor. To use the brush, remove the extension handle from the top-threaded feed tube cap and screw the brush into the handle. Wet the brush with fresh water, hold the feed tubes over the tablet feeder and gently swab the inside of each feed tube. Lower the brush into the tablet feeder and through the openings in the stationary insert. Clean the flow deck and inside of the feeder. Thoroughly rinse and remove the brush, attach the top-threaded feed tube cap to the handle and reinstall the feed tube into the tablet feeder.

BIO-SANITIZER® DISINFECTING TABLETS

If the tablet feeder is to be used for the disinfection of water or wastewater, a (10 lb., 25 lb., 45 lb. or 100 lb.) supply of Bio-Sanitizer tablets is available from your local distributor. Bio-Sanitizer tablets insure dependable disinfection for water and wastewater treatment system flow and other applications where a predictable long-term source of chlorine is desirable. The tablets are manufactured from pure calcium hypochlorite and contain at least 70% available chlorine. Registered with the USEPA for water and wastewater treatment, the tablets incorporate beveled edges to enhance the chemical dissolution pattern, providing effective and economical bacteria killing power. Each tablet is 2⁵/₈" diameter, compressed to a ¹³/₁₆" thickness, has an approximate weight of 5 ounces and is white in color for easy identification. The chemical application rate of the tablets remains consistent at peak flow factors as high as four.

CAUTION: The improper handling of Bio-Sanitizer tablets may cause personal injury or property damage. Keep out of the reach of children and do not allow the tablets or feed tubes to contact skin, eyes or clothing. Tablets may be fatal if swallowed and tablet dust is irritating to the eyes, nose and throat. Do not handle the tablets or feed tubes without first carefully reading the product container label and/or the handling and storage instructions. Do not add tablets to any dispensing device or storage container containing remnants of any other product, especially petroleum based products or swimming pool chlorine. Do not use swimming pool chemicals in Bio-Dynamic tablet feeders. For additional information about Bio-Sanitizer tablets contact your local distributor.

BIO-NEUTRALIZER® DECHLORINATION TABLETS

If the tablet feeder is to be used for the dechlorination of water or wastewater, a (25 lb. or 45 lb.) supply of Bio-Neutralizer tablets is available from your local distributor. Containing 35% sodium sulfite, the tablets are manufactured to neutralize both free and combined chlorine. Bio-Neutralizer tablets incorporate beveled edges to enhance the chemical dissolution pattern. Each tablet is 2⁵/₈" diameter, compressed to a ¹³/₁₆" thickness, weighs approximately 5 ounces and is green in color for easy identification. The tablets dissolve slowly, releasing controlled amounts of chemical for the instantaneous removal of residual chlorine from the water or wastewater flow. The chemical application rate of the tablets remains consistent at peak flow factors as high as four. Bio-Neutralizer tablets are formulated to remove chlorine residuals to non-detectable levels.

CAUTION: Bio-Neutralizer tablets or feed tubes should not be mixed with Bio-Sanitizer tablets or the remnants of any other product. Do not handle tablets or feed tubes without first carefully reading the product container label, MSDS information and the safety, handling and storage instructions. For additional information about Bio-Neutralizer tablets contact your local distributor.

PLACING THE BIO-DYNAMIC® ON-LINE

After adjusting the inlet baffle, filling and installing the feed tubes and selecting the outlet weir or adjusting the outlet sluice, the tablet feeder is ready to be placed on-line. Be sure the entire liquid stream from the facility being served flows through the tablet feeder. Confirm that the proper chemical tablets are being used. After the system has been in operation for at least one hour, draw a sample of the treated effluent from the feeder outlet or the contact chamber inlet to test the chemical application. For chlorination applications, testing can be done using a chlorine test kit, available from your Bio-Dynamic distributor, or a DPD Colorimetric test as outlined in the most recent edition of Standard Methods for the Examination of Water and Wastewater. Multiple samples must be taken to insure that the system has reached equilibrium. Take samples at 15 minute intervals. When three or more samples produce the same results, the system has reached equilibrium.

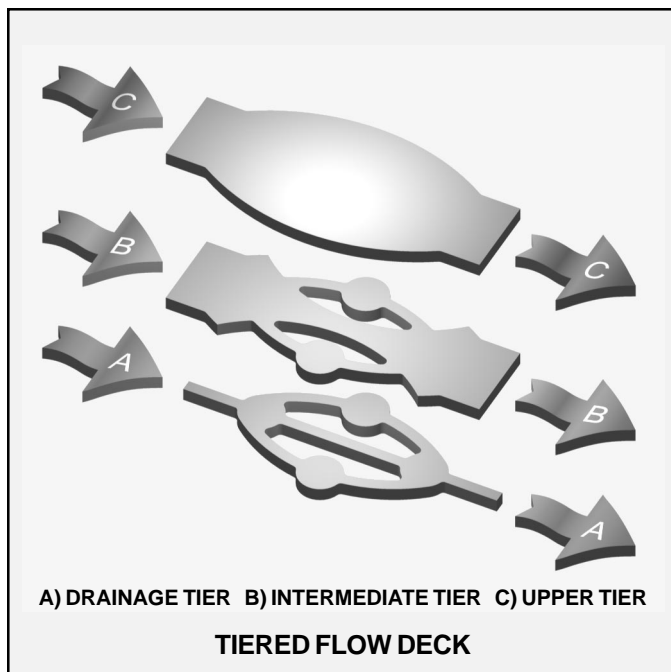

OPERATIONAL ADJUSTMENT

If the chemical dosage requires alteration, the Series 4000 tablet feeder can be adjusted during operation. You do not need to take the system off-line or to disassemble any component of the unit. Chemical application can be increased by decreasing the width of the weir or sluice and also by raising the inlet baffle. Conversely, chemical dosage can be decreased by increasing the width of the weir or sluice and by lowering the inlet baffle. The precise control provided by the Series 4000 tablet feeder allows adjustment of the chemical dosage to almost any requirement while all feed tubes are charged with tablets. Adjustment of the chemical dosage and potential operational problems are covered in this manual. If there are additional questions regarding operation, contact your local Bio-Dynamic distributor. For further reference, a red identification tag with the contact information of the manufacturer is attached to the feeder.

ROUTINE MAINTENANCE

The tablet feeder requires very little maintenance other than periodic cleaning and refilling of the feed tubes. When performing any maintenance, always wear rubber gloves and safety goggles or a face shield and follow the procedures outlined in the handling instructions for the chemicals used in the feeder. Before refilling the feed tubes, rinse each tube and cap thoroughly with fresh water. Occasionally, a feed tube may need to be cleaned with a brush. When refilling feed tubes, check the inside of the feeder and rinse any residue with a low pressure hose. The liquid flow will normally prevent accumulation of debris during routine operation. Debris that may become lodged within the feeder can be removed with the cleaning brush or a gloved hand.

INSUFFICIENT CHEMICAL APPLICATION

Check to see that the tablets are not jammed in the feed tube. If the tablets are jammed, remove and properly refill the feed tubes. Make sure the feed tubes are resting flat in the flow deck retaining rings. If the feed tubes are properly filled and resting securely on the flow deck, check the system for a hydraulic overload. Surges over and above the anticipated system flow rate can cause temporary reductions in chemical application. If adjustment of the Bio-Dynamic tablet feeder is necessary, reduce the width of the outlet weir or sluice. The inlet baffle may also be raised to increase chemical dosage. These adjustments can be made during system operation. Test the chemical application after adjustment to confirm the system is performing as desired.

OVER APPLICATION OF CHEMICAL

Too much chemical can be applied if the outlet is restricted. Check the feeder for blockage. If the outlet is not obstructed, increase the width of the outlet weir or sluice. The inlet baffle can also be lowered to reduce chemical application. These adjustments can be made during system operation. If the outlet weir or sluice is at its maximum width and the inlet baffle is at its lowest setting, chemical application can be reduced even further by leaving one or more feed tubes empty. Empty tubes must still be installed within the tablet feeder to maintain the hydraulic flow pattern. The lowest application of chemical is accomplished by placing the filled feed tubes closest to the system outlet. If this application is too low, the filled feed tubes can be placed closest to the system inlet. Test the chemical application after adjustment to confirm the system is performing as desired.

INTERMITTENT USAGE

If a period of intermittent use or extended period of non-use is anticipated, the feed tubes should be removed and stored in a well-ventilated, dry, secure location. Refer to the tablet container label for detailed safety, storage and/or disposal instructions for the chemical tablets. Reinstall the feeder lid securely for the period of time that the system will be unattended. If a cable locking device has been installed, it should be locked during the period of non-use.

